

## LED Indicators

The LED indicators simply indicate that power is present for the unit and the receiver. They are not indicators of power being within an acceptable range.

## Optional Failsafe-switch

The PowerExpander Sport Plus supports the addition of a failsafe switch (optional package). The PowerExpander Sport Plus supports 5-cell NiCd or NiMH battery packs. When using the failsafe-switch, the switch lead is plugged into the input marked "Sw" near the top left of the servo connections as shown on the reference drawing.

Smart-Fly can supply two types of failsafe switches. First is the standard slide switch that most people are familiar with. This is a small slide switch with out a charge jack. The second failsafe-switch is the Pin&Flag switch, where a pin, with a flag on in, is inserted into the switch to turn the system off. To fly, the pin is pulled out of the switch. The advantage of the Pin&Flag switch is that the system cannot accidentally be turned off, as can be the case with a slide switch. The failsafe switch lead can be extended using a standard Futaba extension.

The PowerExpander Sport Plus also supports charging the batteries through the two charge connections denoted by the "C" next to the battery input ports, one on the top of each servo output rail as shown on the reference drawing. The optional failsafe-switch package includes two charge leads and two Ernst charge jack mounts. The charge leads have a Futaba male on one end and a JR male on the other end. You may use these by plugging either end into the PowerExpander Sport Plus and the other end into the charge jack holder.

The charge jacks on the PowerExpander Sport Plus can also be used to connect to a battery meter. One thing to keep in mind when using a battery meter and the failsafe-switch is that the jacks are not switched off when the unit is off so the battery meter will continue to draw power when the unit is turned off.

## Ignition Cutoff

A separate manual is supplied to instruct you on the use of the Ignition Cutoff. The Cutoff channel is determined by using the six-inch jumper supplied. The Futaba male end should be plugged into the port marked "Ig". The other side of the jumper can be inserted in any servo output channel or it can be connected directly to the receiver, for example, on channel nine of a nine-channel receiver.

Additional information and technical help can be found at [www.Smart-Fly.com](http://www.Smart-Fly.com)

**Quest Engineering & Development**  
**1328 East Cottonwood Lane**  
**Phoenix, AZ 85048-4765**  
**Ph: (480) 460-2652 Fax: (480) 460-2653**



# **PowerExpander Sport Plus User Guide**

*Thank you for purchasing the Smart-Fly PowerExpander SportPlus!*

This manual takes you through the installation and operation of the Smart-Fly PowerExpander Sport Plus. The PowerExpander Sport Plus works with 5-cell NiCd/NiMH battery packs. The battery voltage is delivered straight to the servos while a clean, regulated 5.0 volts is sent to your receiver. It also features a built-in Ignition Cutoff transmitter with remote, optically isolated receiver. Features of the PowerExpander Sport Plus are:

- **For use on 40cc to 100cc gas engine planes**
- **Light weight, 1.9oz, 54g**
- **Compact design, footprint is 2.6" x 3.5"**
- **Uses 5-cell NiCd/NiMH battery packs**
- **Inputs protect against cell failure or power shorts**
- **Filtered and regulated 5.0V power to the receiver**
- **LED power indicators for input and receiver power**
- **Fully buffered outputs on all channels**
- **Full filtration of all signals in and out of the unit**
- **Integrated Ignition Cutoff**
- **Can be used with optional failsafe switch**

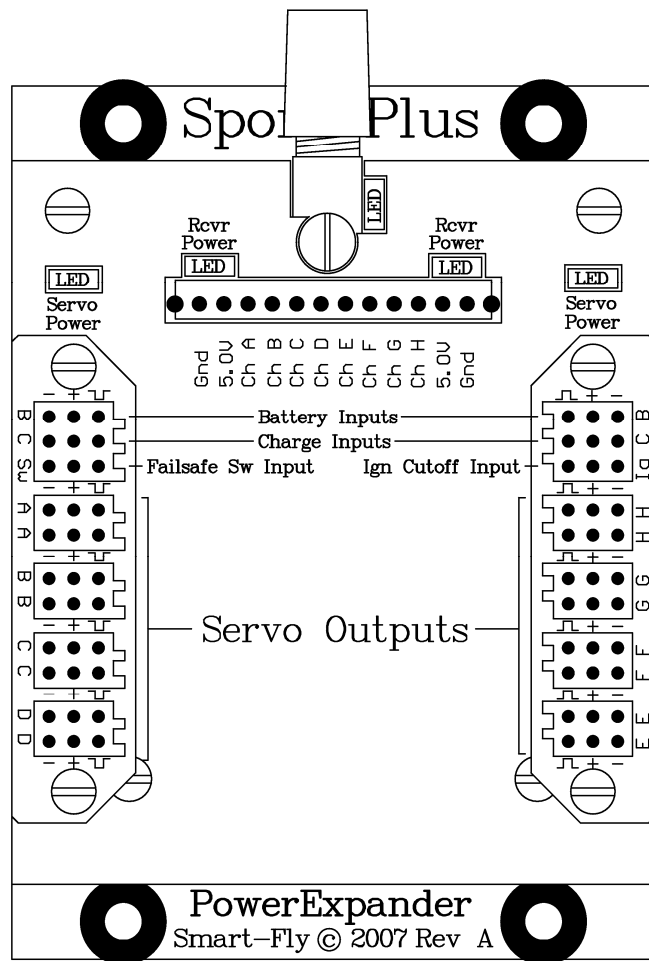

### Receiver Mounting

The receiver mounts in the center of the unit. 3M dual-lock mounting tape has been supplied to mount the receiver. This tape's holding power is extremely strong so it is recommended that the whole 1"x2" piece not be used. Instead it is recommended that you cut some 1"x 1/2" strips and use these on either end of the receiver. You want to keep the pigtails away from the regulator heat-sink. You may want to move the receiver down on the unit, especially end-loading receivers.

### Receiver Connections

The receiver servo outputs are connected to the pigtails coming out of the PowerExpander Sport Plus in the area marked "Channel Inputs From Receiver" on the reference drawing. The two channels on the end ("Chan A" and "Chan H") have power connections to the receiver in addition to the signal connection. It is recommended that if you have a receiver that has less than eight channels that you still use both the end connections as this will provide you with power redundancy to the receiver in event that a power or ground lead should fail.

**CAUTION: Do not plug any receiver pigtails into the battery input of your receiver if it supports Direct Servo Control. Doing so will disable your receiver while the pigtail is plugged in as the receiver will think its in DSC mode.**

The unit will accommodate both end-loading receivers and top-loading receivers. All signals coming from the receiver into the PowerExpander Sport Plus are RF filtered. This prevents noise from the servos from going out the receiver connectors into the receiver. If not all channels are going to be used then the unused pigtail can be tucked away.

### Connections Directly To Receiver

If you want to connect a device directly to the receiver instead of going through the PowerExpander Sport Plus, make sure the current draw of the receiver and the device is less than one amp. We recommend you do not connect servos directly to the receiver.

There are several reasons that a device might be connected directly to the receiver instead of going through the PowerExpander Sport Plus. The most likely would be if you had a nine or ten channel receiver and needed to use the extra channels. Items such as Ignition Cutoffs and smoke pump control do not draw much current and could be used. As long as the combined current draw of the receiver and servo does not exceed one amp this will work just fine.

### Servo Connections

Servos are connected to the PowerExpander Sport Plus along the two rails on either side of the receiver. The servo connectors are universal in that they will work with Futaba or JR connectors. When using a JR connector be careful to observe the polarity of the connection. The ground lead (black on Futaba, brown on JR) is indicated by the "minus" sign, the positive power lead (red on Futaba and JR) is indicated by the "plus" sign and the signal line (white on Futaba, orange on JR) is indicated by the "top hat" symbol.

All receiver channels have each servo signal output individually buffered. If a servo were to short its signal wire, the other servos on that channel would not be affected. All the channels have two servo outputs.

The unit also RF filters each signal output and matches line impedance resulting in a cleaner signal down long servo leads. The impedance matching reduces the electrical "ringing" that can occur on long servo leads. Ringing can generate RF interference and can reduce receiver range.

### Power Connections

5-cell NiCd or NiMH batteries should be used with this unit. The power inputs are protected from each other in case of a dead cell or short. There is a half-volt drop between the input and the servos. It is highly recommended that you use two battery packs for redundancy and to provide extra current to the unit. Power is supplied to the unit through the two ports marked "B" at the top of the servo block.